

Knowledge Driven HealthCare Decision Support System Using Distributed Data Mining

P.T. Kavitha¹ and T.Sasipraba²

¹Research Scholar, Sathyabama University, Chennai - 600 119, Tamil Nadu, India

²Dean, Sathyabama University, Chennai - 600 119, Tamil Nadu, India

E-mail : kavithapt@yahoo.com

(Received on 12 January 2013 and accepted on 18 May 2013)

Abstract - This paper focuses on a web based decision support system which is based on distributed data mining and designed for the healthcare industry. Innumerable Decision Support Systems are prevailing in the market to cater the needs of the various industries based on various purposes. The importance of any Decision Support System resides on the quality of information it provides compared to other information system which leads to take effective decision making. As most of the records in the healthcare industry are maintained manually, the use of Electronic Health Records is introduced recently which will enable the user to have a clear idea about the service he/she wants to utilize. Since it takes a lot of time to retrieve the information from the manually maintained records, use of Electronic Health Records plays a major role in the Healthcare industry. The present Decision Support Systems concentrate on the administration part of the Healthcare industry; their features support the physical practitioner, nurses, pharmacists, administrative personnel. The patients who are the main players in the healthcare industry are mainly concentrated for mapping their behaviour, and whether they will come back to the health care service provider again or not. The decision system which is presented here gives much importance for the patients and will be acting as a framework which can be included in the services provided by the hospitals. The feedback of the patients can rank the healthcare service provider and to improve the quality of their service.

Keywords: Decision Support Systems, Distributed Data Mining, Healthcare Providers

I. INTRODUCTION

The Decision Support Systems can be divided into five broader categories including

1. Communication- driven;
2. Data-driven;
3. Document-driven;
4. Knowledge-driven and
5. Model-driven decision support systems.

Previously managers actually used a Management Decision System (MDS). Marketing and the Production managers used these MDSs for marketing and coordinating with other departments.

Knowledge driven DSS can suggest or recommend actions to managers. The DSS are person-computer systems with specialized problem solving expertise. The “expertise” consists of knowledge about a particular domain, understanding of problems within that domain and “skill” at solving some of these problems.

II. MOTIVATIONS AND RELATED WORK

When considering the development of e-health, one has to bear in mind that there is a long history of Information and Communications Technologies (ICT) use in the health sector. Traditionally, technology has acted as a support for health professionals, in the form of instruments and a whole range of diagnostic and therapeutic devices. More recently, information technologies, and computer software in particular, have extended the scope of their activities to healthcare enterprise management, planning and administration. Now new digital communications technologies, of which the Internet is the most visible paradigm, are opening up their capabilities to all the actors, including patients and general public.

Effective and timely communication between patients, physicians, nurses, pharmacists and other healthcare professionals is vital to good healthcare. Current Communication mechanisms based largely on paper records and prescriptions are old fashioned, inefficient and unreliable.

Decision Support Systems implement ICT to ensure better services to all the actors in the healthcare industry including patients and general public. A Decision Support System (DSS) which incorporates Interactive Voice Response

System (IVRS) to collect information from health workers through their mobiles, software modules to update data from IVRS to Database server automatically.

A Model Driven Decision Support system that facilitates load balancing and decentralization to strengthen primary health care services within a geographical region and in manpower and equipment requirement planning, based on patient load, instead of fixed administrative guide lines.

Medical Diagnosis by learning pattern through the collected data of diabetes, hepatitis and heart diseases and to develop intelligent medical decision support systems to help the physicians.

Healthcare providers and Governments have no choice but to meet healthcare demands for future citizens and the application of e-health is therefore fundamental.

A Health care delivery model based on mobile technology as an information transmission tool between rural patients and centrally located providers, using trained intermediaries as a local facilitators, entrepreneurs and health activists[5].

A Health care system which collects diagnosis patterns classifies them into normal and emergency terms and declares emergency by comparing the two data groups and suggests methods to analyze and model patterns of patients' normal and emergency status.

A Clinical decision support system to healthcare practitioners in rural or remote areas for young infants.

The challenge, as much of our time as of times to come, is to ensure that these new possibilities (which new technologies make available to us) are disseminated and distributed as widely as possible, serve to improve the quality of life and well being of the general public and, lastly, help reduce imbalances and inequalities in society while favouring the development of the economy. In brief it is a, matter of advancing, not merely towards a better interconnected but rather towards a better integrated world.

The work presented aims at establishing a novel paradigm for an intelligent and interactive one, which is capable of estimating the user's health status and which can provide alerts and information regarding the current status and context of the user, as well as regarding alarming health trends.

Autonomous, reactive and proactive intelligent agents provide an opportunity to generate end user oriented, packaged, value added decision support / strategic planning services for healthcare professionals as managers.

The decision support system is representing the interconnected and integrated world of healthcare.

These existing approaches for Distributed Data Mining suffer from one or more of the following disadvantages:

1. All the healthcare management systems resemble hospital management systems;
2. Importance has been given to the administration procedures and implementations;
3. Many healthcare decision support system need to be interconnected to ensure information exchange. Interconnectivity increases exposure of risk of damage, loss and fraud. Security and privacy of patient's information are concerns of all healthcare organizations;
4. Some Decision Support Systems depend on the doctors.

Clinical Decision Support tool was designed to complement Village Health Centre's cognitive abilities to collect comprehensive clinical information and assist local decision making. An efficient use of bandwidth allowed the data to be populated on a web based EMR that could be remotely accessed and served by doctors.

The scope of e-health applications includes different lines of development, which can be classified as

- a. Information Services
- b. E-Commerce
- c. Electronic Connectivity and Messaging
- d. Online Computer Software Application
- e. Medical Service

The proposed system has an unique feature is to offer embedded decision support. The Decision Support System mines higher level of information or knowledge from the relational databases. The DSS will monitor several patients and a large amount of data will be created for each customer.

The Decision Support System is the main tool in medical service to cater the needs of the target groups. The target groups for e-health applications can be divided into the elderly, chronically infirm and patients and general public. The patients and general public can be empowered by internet, can be motivated to use the Decision Support System that can enable such targets to get medical assistance and

better decision making. The added feature of the proposed system is the ranking of healthcare service providers using the feedback obtained from the patients.

III. PROPOSED WORK

Moving a step further, early detection and diagnosis of critical health changes could enable prevention of most of these problems, saving billions of dollars annually.

Knowledge from distributed sites is extracted in the form of association rules. Based on the types of values, the association rules can be classified into two categories:

Example:

Boolean Association Rules: Keyboard à Mouse [Support = 6%, confidence = 70%]

Quantitative Association Rules: (Age = 26 ...30) -> (Cars =1, 2) [Support = 3%, confidence = 36%]

Association Rule mining is employed here using KDD algorithm. The unifying goal of the KDD algorithm is to extract knowledge from data in the context of large databases.

The proposed Decision Support System employs the above said algorithm and the ranking methodology is further included to rank the Healthcare Service Provider.

Formal inputs like name, age, symptoms, and preferences will be filled in the entry form which is available on web. Once the patient filled the application form, a Patient Identity Number will be created. The patient or the general public can get the information regarding their diseases, treatments etc.

It is requested that after getting the service from the health care service provider, the patients should give their feedback. Based on the feedback from the patients the ranking will be implemented.

The ranking of the healthcare service provider can provide the following:

- To know the satisfaction level of the patients who utilize the services;
- To improve the quality of service in the healthcare industry using the patient's feedback;
- To inculcate the changes based on the patient's feedback to redesign the services;
- To increase the number of patients who visited the decision support system and to improve the database;

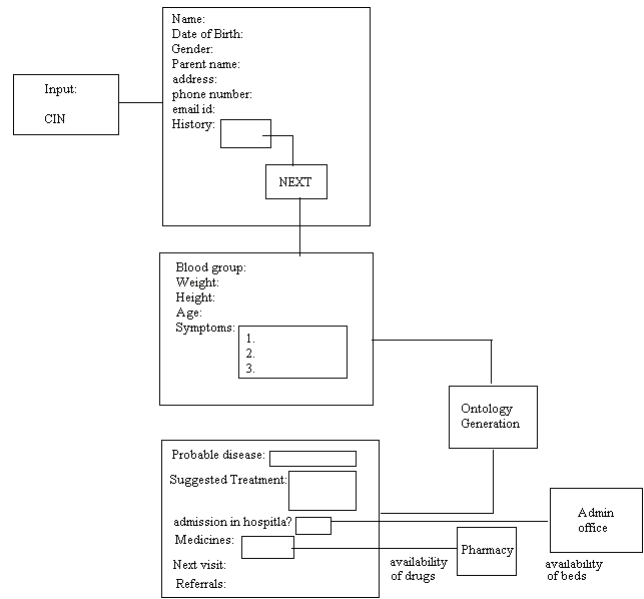

Fig. 1 Details of the Input

- To help the general public for providing information regarding the diseases and treatments;
- To help the allied industries of the healthcare industries like Insurance, Medical Tourism, Pharmaceuticals etc to know the behaviour of the customers/patients so as to cater them with their improved services.

Since our proposed system concentrates on the above points, it can be effectively implemented in rural areas where medical facilities are not in abundant. Scarcity of doctors, nurses, and the inability of the healthcare service provider regarding the quality services lead the designing of the Decision Support System like this.

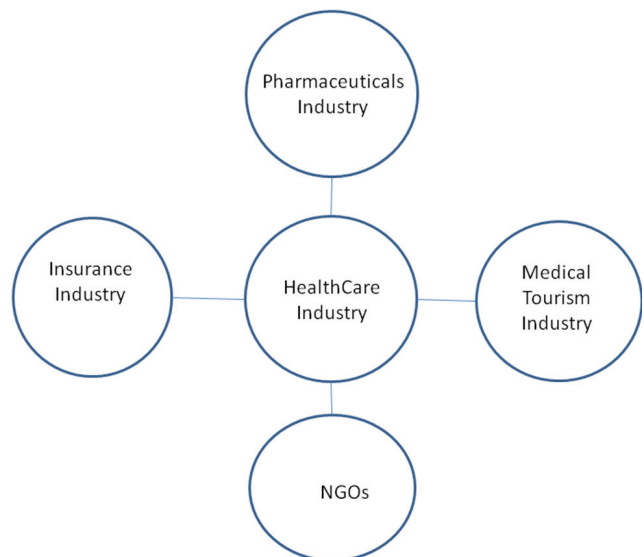

Fig. 2 Dependent Industries

There are many Decision Support Systems available in the market and current scenario depicts the need of a Decision Support System we proposed.

It will be easier for the patients to get the service without spending much money, standing in a long queue to see the doctor, to get the medicines, to get the information about the best services available. The proposed system is highly patient/ customer oriented.

The database is a relational database and the data are updated regular basis. The authenticated administrator can modify, add, delete and update the data. The security and privacy concern is always there when implementing a Decision Supportive System like this. The effective methodologies which are being analysed will be implemented to secure the privacy concerned.

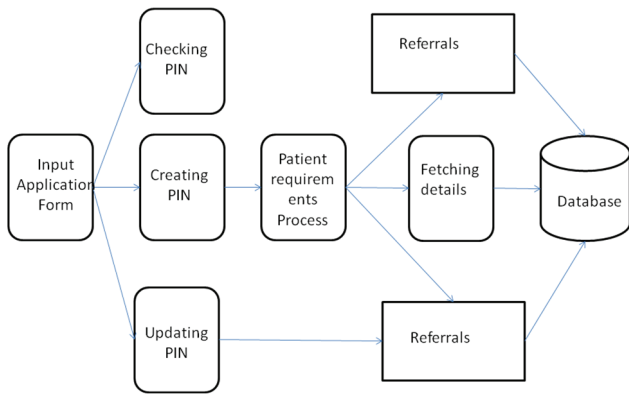

Fig. 3 Data mining in Decision Support System

IV. CONCLUSION AND FUTURE WORK

The proposed framework cannot replace the doctor in anyway. It cannot derive the diagnosis for the patients but it can give useful suggestions and advices regarding the decisions patients make. The decision support system is designed to enhance and support the human.

Further development of the proposed Decision Support System should focus on the following:

- a. Identification and distribution of best practices;
- b. Research about bench marking of DSS;
- c. Questions of Security, data protection and confidentiality;
- d. Quality and authenticity information;
- e. Standardisation and inter operability of DSS;
- f. Co-operation with other health care providers.

Decision Support Systems are susceptible to security attacks. They always contain sensitive information. Medical Ethics should be followed in designing Decision Support Systems.

REFERENCES

- [1] D.J.Power, "A Brief History of Decision Support Systems", Version 4.1
- [2] Manjeet Singh Chalga and Dr.A.K.Dixit, "Development of an ICT based support system for improving Health Care", *International Journal on Computer Science and Engineering (IJCSE)*, Vol.3, No.5, May 2011.
- [3] Rajan Vohra, Nripendra Narayan Das and Meghna Sharma, "Designing a Model Driven Decision Support System for Primary Health Care Managers", *International Journal of Information Technology and Knowledge Management*, Vol.1, No.2, 2008.
- [4] D.SenthilKumar, G.Sathyadevi and S.Sivanesh, "Decision Support System for Medical Diagnosis Using Data Mining", *International Journal of Computer Science Issues*, Vol.8, Issue 3, No.1, May 2011.
- [5] Dr.Priyesh Tiwari, "Providing Services in Rural India: Innovative application of Mobile Technology", *Health Care and Informatics Review Online*, Vol.14, No.2, pp: 3-9, published online at www.hinz.org.nz, 2010.
- [6] Telemedicine and Information Society Research Division, "The e-Health development Framework in Spain", Carlos III Institute of Health,
- [7] Mayuri Gund, Snehal Andhalkar, Prof.Dipti Patil and Dr.V.M.Wadhai, "An Intelligent Architecture for Multi-Agent based m-Health Care System", *International Journal of Computer Trends and Tecchnology*, April 2011
- [8] Vijay Kumar Mago and M. Syamala Devi, "A Multi-agent Medical system for Indian rural infant and child care", *IJCAI 2007*
- [9] Said Jafari, Fredrick Mtenzi, Ronan Fitzpatrick, Brendan O'Shea, "Security Metrics for e-Healthcare Information Systems: A Domain Specific Metrics Approach", *International Journal of Digital Society (IJDA)*, Vol. 1, Issue 4, December 2010.
- [10] P.T.Kavitha, Dr.T.Sasipraba, " Efficient Management of Distributed Rural Children HealthCare Data Mining System using Co-operative Mobile and Static Agents", *National conference at Sona College of Technology*, 2011.
- [11] C. Kalb, "Fixing America's hospitals", *Newsweek Mag*, Vol. 148, pp. 44-46, Oct. 2006.
- [12] E. Berner, "Clinical Decision Support Systems: Theory and Practice", 2nd ed. New York: Springer- Verlag, 2006.
- [13] Alexandros Pantelopoulos, Nikolaos G.Bourbakis, "Prognosis- A Wearable Health-Monitoring System for People at Risk: Methodology and Modelling", *IEEE Transactions on Information Technology in Biomedicine*, Vol.14, No.3, May 2010.
- [14] R.J Richardson, " The Role of e-health", www.medetel.lu, 2006.
- [15] Firat Kart, Locise E.Moser amd P.Michael Melliear-Smith, "Building a Distributed E-Healthcare System using SOA", *IEEE IT Pro*, April 2008.
- [16] Syed Zahid Hassan Zaidi, Syed Sibte Raza Abidi and Selvakumar Manickam, "Distributed Datamining from heterogeneous healthcare data repositories: Towards an Intelligent Agent based Framework", *Proceedings of the 15th IEEE Symposium on Computer based medical systems 2002IEEE*
- [17] M.Senthil Velmurugan, Kogilah Narayanaswamy, "Application of Decision Support System in E-Commerce", *Communications of the IBIMA*, Vol.5, 2008