

Wavelength Converter Based Optimized RWA for All Optical Networks

Shilpa S. Patil¹ and Bharat S. Chaudhari²

^{1&2}Maharashtra Institute of Technology, Pune, Maharashtra, India
 E-Mail: bsc@ieee.org

(Received 13 April 2019; Revised 23 April 2019; Accepted 5 May 2019; Available online 10 May 2019)

Abstract - Wavelength converters are used in WDM networks to avoid call blocking and minimizing the blocking probability. Optimal placement of wavelength converters restricts the call blocking probability, the complexity and improves the overall network performance of the network. In this paper, we propose a new weight dependent routing and wavelength assignment algorithm for the optimal placement of the wavelength converters. The wavelength converter placement was considered separately at all the nodes and the partial nodes. Our algorithm outperforms the previously reported studies and requires a lesser number of wavelength converters to achieve the required performance. It reduces the blocking probabilities up to 5.4% and shows that the first four nodes primarily control the blocking performance of the network. The study also reveals that instead of merely increasing the number of converters, their placement at the right location plays a crucial role in improving the performance. Initially, although an increase in the number of the wavelengths also improves the network performance, the further increase does not contribute much to the reduction of the blocking probability.

Keywords: Blocking Probability, All Optical Networks, Wavelength Converters, Routing and Wavelength Assignment

I. INTRODUCTION

Wavelength division multiplexing (WDM) in optical networks provides ultra-high-speed transmission capabilities with a very high quality of service (QoS), supporting real- and non-real time applications. All-optical networks (AONs) aggregate the data coming from access and distribution networks [1] and transmits end-to-end in the optical domain. A lightpath can be established between end-to-end or any two nodes on the route, bypassing the electronic processing at intermediate nodes. For each connection, sender node searches for the best possible route and allocates a wavelength from the available pool of free wavelengths at that time. This task is known as routing and wavelength assignment (RWA) [2]. Wherever possible, a lightpath uses the same transmission wavelength for end-to-end connection. Many times availability of the same wavelength on all the links and segments on the route becomes a restriction known as single wavelength continuity constraint. Ultimately, it increases the overall probability of call blocking degrading the performance of the network. Impact of this constraint can be diminished by placing the wavelength converters (WCs) in the network. Though numerous researches have been carried out on AON, the design of optimal RWA strategy in the presence of WCs has remained a challenge [3], [4]. WCs [5]-[7] convert a wavelength of the incoming signal into different

free wavelength, improving the blocking performance. Optical nodes can have the capability to convert the wavelengths at all the nodes as per the requirement is shown in Fig. 1. In another case, the network can have a few select nodes with such capability as shown in Fig. 2.

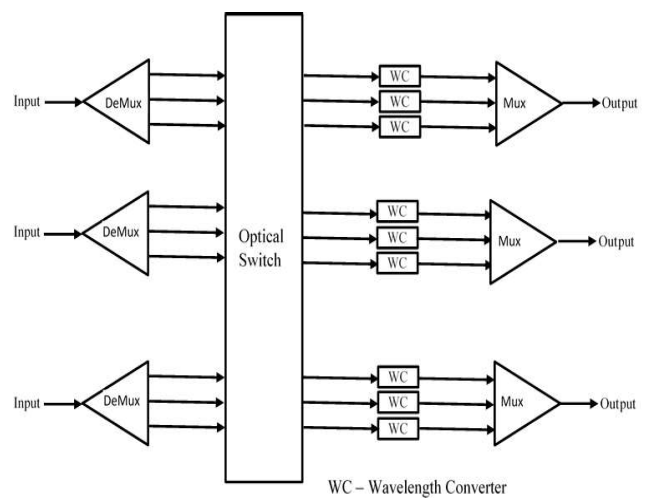

Fig. 1 Full wavelength converters architecture

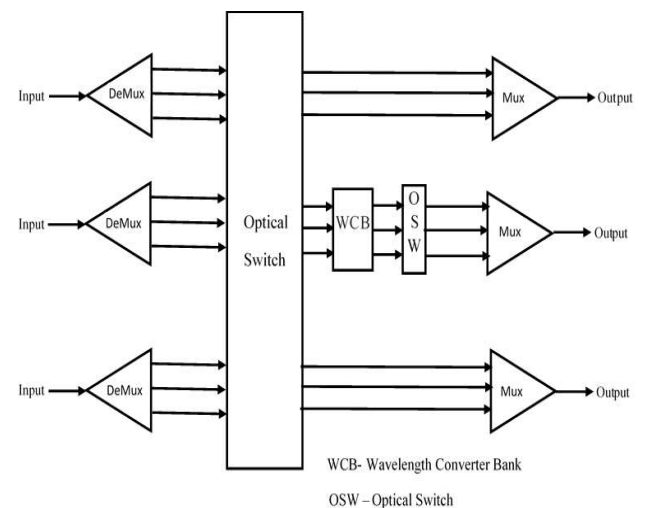

Fig. 2 Partial wavelength converters architecture

In full-wavelength converters, each port of optical switch has dedicated WC, and all the incoming wavelengths are converted to any other wavelengths simultaneously. In partial wavelength converters, the WCs are installed only at a few select nodes, making the system cost-effective. Switching of multiple wavelengths by using waveband

switching [8] enables routing of multiple wavelengths to the same destination, but still, the availability of specific wavelengths of a waveband at every node remains a challenge. In partial wavelength converters, placement of the optimum number of WCs without degrading the performance, increasing the complexity and cost in multi-hop carrier-class optical networks is still a challenge. This paper presents a novel RWA algorithm for the placement of the optimal number of WCs in AONs. The rest of the paper is organized as follows: Section II presents a literature review of WC placements. Section III outlines the proposed RWA algorithm for full- and partial WC placement. The results and discussion are presented in Section IV, and the paper is concluded in Section V.

II. RELATED WORK

The blocking performance of the optical networks with wavelength converters (WCs) is better than that of without WCs. Primarily, the blocking performance of AON depends upon the factors such as topology and size of the network, traffic, the number of wavelengths and hops required for each connection, and presence and placements of WCs. Based on the relatively smaller number of nodes with wavelength conversion capabilities; one can reduce the blocking probability in the network. Placement of wavelength converters is studied [9], [10] and shown that the optimal placement of these converters with heuristic and metaheuristic approach improves the performance [11]-[14]. For partial wavelength conversion, minimum blocking probability First (MBPF) [12] is used to place wavelength convertible routers. Weighted least congestion routing first fit (WLCR-FF) [11] with MBPF inserts one converter each time during the simulation and calculates the blocking probability, ensuring the placement for minimum blocking probability. It is showed that WLCR-FF improves the blocking performance for the full as well as partial WCs; however, it incorporates delay in the computation.

K-minimum dominating set of networks graph [15] approach selects only the nodes with full range WCs available. However, it does not consider the nodes with few WCs, available wavelengths at that time, and non-uniform traffic. Integer linear programming method for optimal placement of WCs for static traffic [16] considers RWA and WC both at the same time, making it complex and difficult to apply in real time networks. Minimum converter allocation (MCA) [17] improves the utilization of wavelength converters and requires maximum of 5% wavelength converters at a given time. With the help of link state information [3], WC placement is on the auxiliary graph. Intermediate node WCs are placed depending on their usage in the past. For the selection of the path least loaded routing (LLR) is used. Accuracy in the blocking probabilities for different traffic classes and patterns are compared [18]. Optimized WC placement approach with tunable and fixed transceivers [19] shows that sparse partial WCs for different load scenarios require only 2.4% converters. The study of adaptive alternate routing [20] is

undertaken for various scenarios such as load distribution, traffic patterns, network topologies, adaptive alternative routes and number of converters. The bandwidth-utilized rate can be enhanced by wavelength tuning in optical networks. Sparse wavelength tuning or conversion improves network BER performance. Provision for the alternate paths can also reduce the calling blocking. The literature study shows that though several types of research have been carried out for improving the blocking performance of AON, the optimal placement of WCs is an open issue and requires further study. We propose a novel weight dependent RWA algorithm with optimal WCs to further improve the performance of AONs.

III. PROPOSED OPTIMIZED RWA WITH WAVELENGTH CONVERTERS

The objective is to optimize the number of WC required in the AON and reduce the call blocking probability. We have considered WDM NSF net topology with 21 bidirectional links and 14 nodes as shown in below Fig. 3.

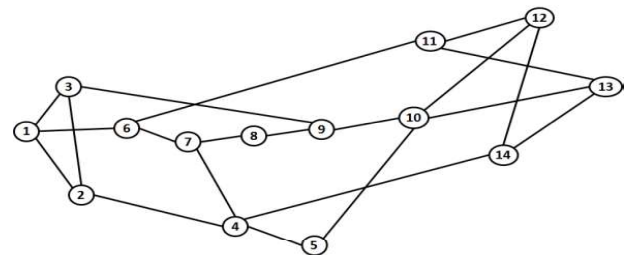

Fig. 3 NSFnet topology

The memoryless Poisson distribution is used to analyze the traffic on the network. For a random variable $X(t)$ with known probability distribution function at the time t , the inter-arrival call process is defined by non-negative random sequence $A(n)$ The n -th inter-arrival time is described by the exponential distribution with mean arrival rate parameter λ as

$$P\{A(n) \leq t\} = (1 - e^{-\lambda t}) \quad (1)$$

The number of arrivals in an interval of time t and counting process is described by

$$P\{N(t) = n\} = \frac{(\lambda t)^n e^{-\lambda t}}{n!} \quad (2)$$

We define the number of the nodes in the network as

$$N := \{n \mid n \in N, 1 \leq n \leq 14\} \quad (3)$$

The number of bi-directional links in the networks as

$$L := \{l \mid l \in N, 1 \leq l \leq 21\} \quad (4)$$

$$:= \{(s_i, d_i) \mid s_i \neq d_i, i \in N\} \quad (5)$$

where s and d are the source and destination nodes, respectively.

Total number of paths for each source and destination pair, P_n can be written as

$$\begin{aligned} Paths := P_n &:= \{\{p\}\} \\ &:= \{(s_1, d_1), (s_2, d_2), (s_3, d_3), \dots, (s_n, d_n)\} \mid s_i \neq d_i, n \in P_n, i \in N \end{aligned} \quad (6)$$

The traffic distributed uniformly for exponential call holding time with an average of $1/\mu$. We use the weighted dynamic routing algorithm to select the route with the

maximum weight value. By computing K -shortest routes offline and weight values by considering the availability of resources, the selected route is written as

$$P^k_{W, \max} = \arg \max_{k=1 \text{ to } 18} \left(\frac{(W^a)(T_e) \left(\sum_{i=1}^{Pl} S_c(i) \right)}{\left[\left(\sum_{i=1}^{Pl} S_c(i) \right) + \left(\sum_{i=1}^{Pl} B_c(i) \right) \right] \left(\sum_{i=1}^{Pl} H_t(i) \right)} \right) \quad (7)$$

where total available wavelengths are W^a for k routes, T_e is time elapsed, $S_c(i)$ is served calls, $B_c(i)$ is blocked calls, and $H_t(i)$ is total call holding time of served calls. W^s is selected wavelength as $W^a(1)$. For new requests, shortest paths are calculated. K -shortest path with the highest weight is selected as a route. With this dynamic routing and first fit as wavelength assignment scheme, if the wavelength is not available, then it uses the wavelength converters. When the converters are used, the shortest path with $k = 1$ is used. For other values of k , it may require more number of hops resulting varied requirement of wavelengths and increase in complexity. We applied the developed algorithm for both the scenarios, viz. WCs at all the nodes and at selected nodes to enabled us the performance comparison among themselves as well as with the previously reported literature.

A. Wavelength Converters at all the Nodes:

In this case, all the nodes of the network have full range WCs. From the pool of available wavelengths, a light path is searched, and wherever the continuous wavelength is not available, then a WC is used to convert a wavelength of the incoming signal into a different but available wavelength. Thus call gets completed and removes the wavelength continuity constraint improving the blocking probability. However, placing WCs at all the nodes is not a feasible solution because all the WCs are not used at a time and also increase in cost and complexity.

B. Wavelength Converters at Selected Nodes (Partial Wavelength Conversion):

Instead of WCs at all the nodes, a very few select nodes have wavelength conversion capability. For the placement of WCs, finding out their optimum locations is a very crucial task. We used K-means clustering algorithm to generate clusters as per the requirement. Initially, call blocking probabilities without WCs are used as input for the K -means clustering algorithm to minimize the objective function as

$$\arg \min = \sum_{i=1}^k \sum_{X \in S_i} \|X - \mu_i\|^2 \quad (8)$$

where μ_i is the mean of points in S_i . Given a set of observations $X = \{X_i | 1 \leq i \leq n\}$ where each observation is a d -dimensional real vector, K -means clustering aims to

partition the n . Observations into $k (\leq n)$ sets $S = \{S_i | 1 \leq i \leq k\}$ so as to minimize the intracluster sum of squares. When the lightpath request arrives in the network, and same wavelength is not available at all the segments or links till the destination then one of the free wavelengths is searched in such a way that the said wavelength is available from the sending node to one of the farthest nodes with wavelength conversion capability. In this case, no wavelength conversion is required until the farthest node. The farthest node carries out wavelength conversion to establish the call till destination. If the single free wavelength is not available, again this node searches for second farthest node towards the destination and repeats the process. WCs are placed systematically at the nodes which are handling higher traffic and blocks maximum calls. The wavelength conversion process may be performed multiple times at different nodes to complete the call.

$$\text{if ConvLoc}(s, d) = \text{True then} \quad (9)$$

ConvLoc is the location of a converter in the network.

$$\text{if } W_{a_All}(i) \neq \phi \text{ then} \quad (10)$$

where W_{a_All} is the total number of wavelengths. For using wavelength converters of that position,

$$W_c^a(i) := W_{a_All}(i) \quad (11)$$

From the set of the available wavelengths, the common wavelength is selected on all the links.

$$W_1^a = W^a(1) \cap W^a(2) \cap W^a(3) \cap \dots \cap W^a_{length}(W^a) \quad (12)$$

The non-available wavelength is converted into available wavelength which is common on all links.

$$W_c^a = W_c^a \cup W_1^a \quad (13)$$

Steps for placing the converters are:

1. Initialize the traffic for one hour.
2. Run the network for one hour with a new dynamic RWA algorithm without WC.
3. Find out the nodes with their blocking probabilities.
4. Use K -Means clustering algorithm for finding out the two separate groups of blocking probabilities from all nodes. The inputs for the algorithm are blocking probabilities of each node which has calculated without wavelength converters.
5. Select the cluster having nodes with maximum blocking probability for the placement of WCs.
6. Place the WCs at the above-selected nodes and rerun the network. paper submission

IV. SIMULATION, RESULTS AND DISCUSSION

We perform the extensive simulations for WDM NSFnet. For the dynamic RWA algorithm with wavelength converters, blocking probability is obtained and analyzed for full WCs and partial WCs. The results are compared for partial WCs with shortest path routing first fit wavelength assignment [11] and least loaded routing first fit wavelength assignment [12] algorithms. The simulation results are acquired for low traffic load from 170 E to 240 E for 40 wavelengths as shown in Fig. 4. The results show that the proposed algorithm outperforms and reduces the blocking probability by 5% than SPR-FF [11] with partial WC. For the high load of 840 E to 1080 E for 120 wavelengths, the blocking probability reduces up to 5.4% than SPR as shown in Fig. 5. It also illustrates that the difference between blocking probabilities for full and partial placement of WCs is small and hence the proper placement of partial WCs achieves better results.

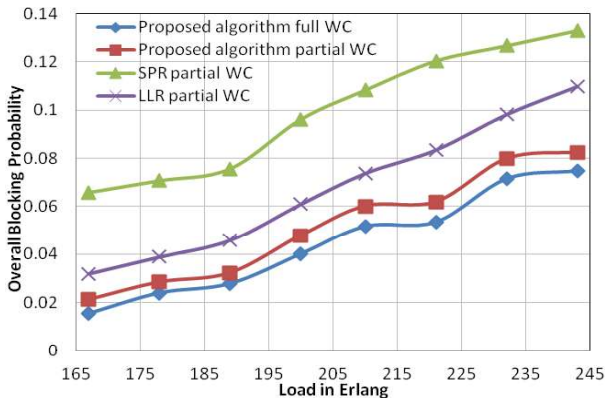

Fig. 4 Overall blocking probabilities for a low load with 40 wavelengths

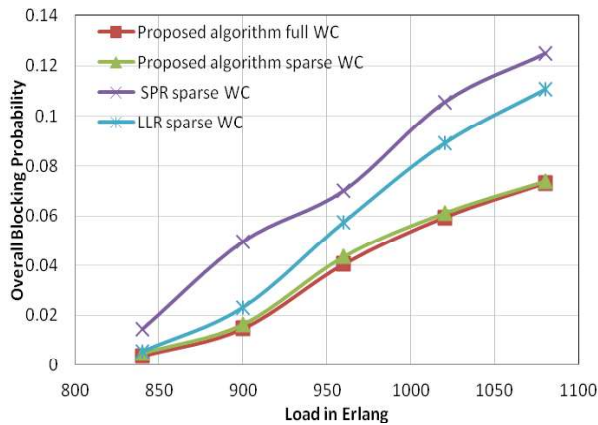

Fig. 5 Overall blocking probabilities for a high load with 120 wavelengths

Table I shows the comparison of blocking probabilities for different previously reported routing algorithms and proposed algorithm without WC. Our weight based dynamic RWA outperforms over the other. It shows that with an increase in traffic, there is a slight increase in blocking, but it is not a linear relation.

TABLE I COMPARISON OF BLOCKING PROBABILITIES FOR DIFFERENT ROUTING ALGORITHMS

Wave lengths	Load	SPR [11]	LLR [12]	WLCR [12]	Proposed RWA
W=40	190E	0.07566	0.034586	0.04335	0.035126
W=40	210E	0.109771	0.069797	0.06775	0.062877
W=120	840E	0.051969	0.005510	0.006213	0.00510
W=120	960E	0.095301	0.054825	0.053413	0.04501

For partial WCs placement, we have selected the first four nodes which reject more call requests for placing the WCs. The results in Fig. 6 show that merely increasing WCs do not show much deviation in blocking probability. It can be seen that the maximum change in blocking performance is around 1 % for the increase in the number of converters from 2 to 14. Hence, placing more number of WCs in the network may not be beneficial if they are not placed at right places. The result also shows that although more numbers of converters are deployed still there is slight fluctuation in the blocking due to unavailability of wavelength or route to the destination or sudden increase in traffic in the network.

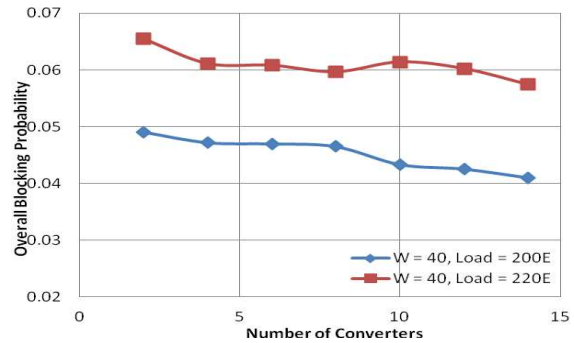

Fig. 6 Overall blocking probabilities versus the number of WCs for a low load with 40 wavelengths

In addition to the placement of WCs, one must consider how much the total number of wavelengths is available in the network. To study their impact, simulations were carried for blocking probability. Fig.7 shows that effect of the number of wavelengths on the blocking probability in a network with proposed RWA and WLCR algorithms and using First-fit wavelength assignment techniques [12].

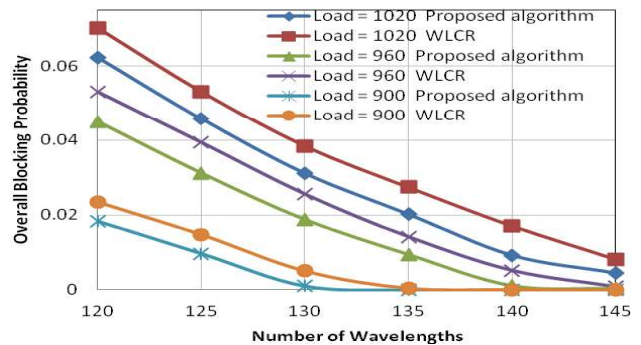

Fig.7 Overall blocking probabilities versus the number of wavelengths for high load

The results show that if the number of wavelengths in the network are increased, the blocking probability is reduced from 6.2% (with 120 wavelengths) to 1% (with 140 wavelengths) which much better than earlier reported results. It can also be seen that further increase in the number of wavelengths does not contribute much to the reduction of blocking probability.

V. CONCLUSION

In this paper, we propose a new dynamic weight based RWA algorithm with full and partial wavelength converters. The results show that there is not much change in blocking probability between full and partial wavelength converter scenarios provided wavelength converters are placed at right nodes in the network. With the increase in the number of converters, blocking probability reduces, but after the first four converters, there is not much reduction. The study shows that our algorithm reduces the blocking probability by 5.4% in comparison with previously reported studies and has low complexity and cost. It shows that through the blocking performance is controlled by the number of wavelength in the networks; further increase in wavelengths does not contribute much in the performance improvement.

REFERENCES

- [1] S. Turk, "Network migration optimization using meta-heuristics," *International Journal of Electronics and Communication*, Vol. 68, No. 7, pp. 584-586, 2014.
- [2] L. Tseng-Kuei, M. J. Chien, J. C. Chen, and H. Tsai, "Routing and wavelength assignment for augmented cubes in array-based wavelength-division-multiplexing optical networks," *International Journal of Computer Mathematics: Computer Systems Theory*, Vol. 3, No. 2, pp. 1-14, 2018.
- [3] Y. Fukushima, T. Ooishi, and T. Yokohira, "A wavelength and converter assignment scheme using converter usage history in wavelength-routed networks," *International Journal of Computer Networks & Communications*, Vol. 5, No.4, pp. 63-73, July 2013.
- [4] M. L. Andre, L. Miranda, F. Lima, H. Rocha, N. Vijaykumar, R. L. Carlos, M. Segatto, and J. Costa, "Assignment using a hybrid evolutionary computation to reduce crossphase modulation," *Journal of Microwaves, Optoelectronics and Electromagnetic Applications*, Vol. 13, No. 1, pp. 1-15, June 2014.
- [5] C. Siva Ram Murthy, M. Gurusamy, *WDM Optical Networks Concepts, Design and Algorithms*. New Delhi: PHI Learning Pvt. Ltd, 2002.
- [6] X. Wang, I. Kim, Q. Zhang, P. Palacharla and T. Ikeuchi, "Efficient all-optical wavelength converter placement and wavelength assignment in optical networks," *2016 Optical Fiber Communications Conference and Exhibition (OFC)*, Anaheim, CA, 2016, pp. 1-3.
- [7] I. Kiyo, T. Inoue, I. Kim, X. Wang, H. N. Tan, Q. Zhang, T. Ikeuchi, and S. Namiki, "Analysis and demonstration of network utilization improvement through format-agnostic multi-channel wavelength converters," *IEEE/OSA Journal of Optical Communications and Networking*, Vol. 10, No. 2, pp. A165-A174, 2018.
- [8] A. N. Khan, "Computing approximate blocking probabilities for transparent waveband switching based WDM networks using hierarchical cross-connects," *International Journal of Electronics and Communication*, Vol. 84, pp. 265-272, 2018.
- [9] S. Gao, X. Jia, C. Huang, and D. Duan, "Optimization model for placement of wavelength converters to minimize blocking probability in WDM networks," *Journal of Light wave Technology*, Vol. 21, No. 3, pp. 684-694, 2003.
- [10] I. Kim, X. Wang, P. Palacharla, and T. Ikeuchi, "Placement of wavelength shifters in optical networks," *U.S. Patent*, 9973383, 2018.
- [11] X. W. Chu, B. Li, and I. Chlamtac, "Wavelength converter placement for different RWA algorithms in wavelength-routed all-optical networks," *IEEE Transactions on Communications*, Vol. 51, No. 4, pp. 607-617, 2003.
- [12] X. W. Chu, B. Li, and Z. Zhang, "Dynamic routing and wavelength assignment in the presence of wavelength conversion for all-optical networks," *IEEE/ACM Transactions on Networking*, Vol. 13, No. 3, pp. 704-715, 2005.
- [13] M. Hadi and M. R. Pakravan, "Spectrum-convertible BVWC placement in OFDM based elastic optical networks," *IEEE Photonics*, Vol. 9, No. 1, pp. 1-12, 2017.
- [14] A. Rodriguez, L. Ramirez, and J. Martinez, "Heuristic algorithms: novel solution for RWA problem in WDM optical networks," *Journal of Telecommunication, Electronic and Computer Engineering*, Vol. 10, No. 1-4, pp. 1-7, 2018.
- [15] M. Houmaidi and M. A. Bassiouni, "Dominating set algorithms for sparse placement of full and limited wavelength converters in WDM optical networks," *Journal of Optical Networking*, Vol. 2, No. 6, pp. 162-177, 2003.
- [16] P. N. Tran and U. Killat, "An exact ILP formulation for optimal wavelength converter usage and placement in WDM networks," *IEEE Global Telecommunications Conference*, pp. 1-6, 2008.
- [17] X. Masip-Bruin, M. German, and A. Castro, "The minimum coincidence routing approach in wavelength-routed optical WDM networks," *2009 Latin American Network Operations and Management Symposium*, pp. 1-5, 2009.
- [18] M. Wang, S. Li, E. W. M. Wong, and M. Zukerman, "performance analysis of circuit switched multi-service multi-rate networks with alternative routing," *Journal of Light wave Technology*, Vol. 32, No. 2, pp. 179-200, 2014.
- [19] S. S. Patil and B. S. Chaudhari, "Placement of wavelength converters in dynamically routed all optical networks in presence of tunable transceivers," *J of Network Protocols and Algorithms*, Vol. 7, No. 4, pp. 26-36, 2016.
- [20] I. Katib and D. Medhi, "Adaptive alternate routing in WDM networks and its performance tradeoffs in the presence of wavelength converters," *Elsevier Optical Switching and Networking*, Vol. 6, No. 9, pp. 181-193, 2009.